



SUREPOWR™ SERIES - SURE 100

FIELD INSTALLATION INSTRUCTIONS

Safety First

In the maintenance and operation of mechanical equipment, SAFETY is the basic factor which must be considered at all times. Through the use of the proper clothes, tools and methods of handling, serious accidents causing injury to you or your fellow workers can be prevented.

Throughout this manual are listed a number of safety precautions. Study them carefully and follow them; also insist that those working for you do the same. Remember, an accident is usually caused by someone's carelessness, neglect or oversight.



To prevent ignition of hazardous atmospheres,
do not remove actuator cover while circuits are live.



Loaded spring inside actuator. Do not attempt to repair actuator
below top gear plate, unless properly trained on repair methods.



Installation

Note: SurePowr actuators can be supplied for clockwise or counter-clockwise spring driven rotation (viewed from the top of the actuator). The spring drive rotation is noted on the actuator name tag and wiring diagram. Ensure that the actuator has been supplied with the proper spring drive operation for the application prior to installation on the driven device.

1. The actuator is shipped in the power off (fail) position. Ensure that the driven device is orientated to its fail position prior to installation of the actuator.
2. Care should be taken to maintain proper alignment between the actuator and the device shaft. If the actuator is not in the correct alignment with the device shaft, repeat the procedure in Step 1.
3. Mount the actuator to the device. Ensure the actuator is centered properly with the device shaft, and then tighten all bolts and nuts evenly.
4. Remove the cover bolts located around the actuator motor and control cover flange.
5. Terminate field wiring per the appropriate RCS wiring diagram, supplied with the actuator. Use a minimum of #18 AWG stranded wire.

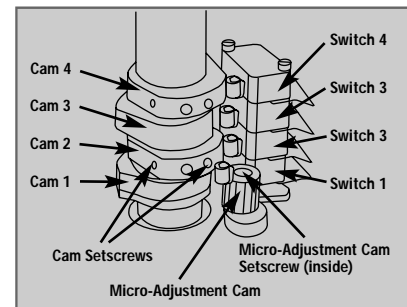

Figure 1

Note: Ensure the driven device is properly positioned in its full fail position. If it is not, use the adjustable end of travel stop on the Sure 100 (see figure 4) to properly adjust the fail end of travel stop. Only the fail end of travel may be adjusted. Loosen the lock nut to free the adjusting screw, then use a wrench to turn the screw. The total adjustment available is +/- 5 degrees.

Switch adjustments for clockwise spring fail operation (viewed from the top of the actuator)

- a. Ensure actuator is de-energized and positioned in the clockwise (fail) position. Ensure the end of travel stop is properly adjusted. Rotate the screw clockwise to move the actuator output shaft in a counter-clockwise direction. Rotate the screw in a counter-clockwise direction to move the actuator output shaft in a clockwise direction. Loosen the setscrews on Cams 1 and 3. Rotate both counter-clockwise until they clear the switch arm rollers of Switches 1 and 3.
- b. Rotate Cam 1 clockwise until it comes in contact with Switch 1's arm roller and the switch "breaks". A light "click" can be heard. Tighten the set-screws on Cam 1.
- c. Rotate Cam 3 clockwise until it comes in contact with Switch 3's arm roller and the switch just "breaks". A light "click" can be heard.
- d. Rotate Cam 3 slightly further in the clockwise direction. This ensures that Switch 3 will "break" just prior to the actuator reaching the full fail position. Tighten the setscrews on Cam 3. Energize the actuator. This will move the actuator to the opposite end of travel.



SURE 100



Closely monitor the electrical stroke, as the travel limit switches are not yet properly adjusted. Ensure the actuator does not over-travel and damage the driven equipment.



- e. Upon reaching the opposite end of travel, Cam 2 should just engage the roller on Switch 2 so that the switch just “breaks”. This action will stop the actuator. Check that the actuator has properly positioned the driven equipment.
- f. If actuator travel is insufficient, rotate Cam 2 slightly clockwise until the cam just clears the roller of Switch 2. As soon as the cam clears the roller, the actuator will “bump” electrically towards the end of travel. Continue until the actuator reaches the full end of travel.
- g. If the actuator has over-traveled, rotate Cam 2 slightly counter-clockwise, then move the actuator towards the fail position electrically. Stop and electrically reverse the direction of travel. Move the actuator until Cam 2 operates Switch 2 and the actuator stops. Repeat this procedure until the actuator is properly positioned.
- h. Rotate Cam 4 until it comes in contact with Switch 4’s arm roller and the switch just “breaks”. A light “click” can be heard. Rotate the cam slightly counter-clockwise. This ensures that Switch 4 will “break” just prior to the actuator reaching the extreme opposite end of travel. Tighten the setscrews on Cams 2 and 4.

Switch adjustments for counter-clockwise spring fail operation (viewed from the top of the actuator)

- a. Ensure the actuator is de-energized and positioned in the counter-clockwise (fail) position. Ensure the end of travel stop is properly adjusted. Rotate the screw counter-clockwise to move the actuator output shaft in a counter-clockwise direction. Rotate the screw in a clockwise direction to move the actuator output shaft in a clockwise direction. Loosen the setscrews on Cams 2 and 4. Rotate both clockwise until they clear the switch arm rollers of switches 2 and 4.
- b. Rotate Cam 2 counter-clockwise until it comes in contact with Switch 2’s roller arm and the switch “breaks”. A light “click” can be heard. Tighten the setscrews on Cam 2.
- c. Rotate Cam 4 counter-clockwise until it comes in contact with Switch 4’s arm roller and the switch just “breaks”. A light “click” can be heard.
- d. Rotate Cam 4 slightly further in the counter-clockwise direction. This ensures that Switch 4 will “break” just prior to the actuator reaching the full fail position. Tighten the setscrews on Cam 4. Energize the actuator. This will move the actuator to the opposite end of travel.



Closely monitor the electrical stroke, as the travel limit switches are not yet properly adjusted. Ensure the actuator does not over-travel and damage the driven equipment.



- e. Upon reaching the opposite end of travel, Cam 1 should just engage the roller on Switch 1 so that the switch just “breaks”. This action will stop the actuator. Check that the actuator has properly positioned the driven equipment.
 - f. If actuator travel is insufficient, rotate Cam 1 slightly counter-clockwise until the cam just clears the roller of Switch 1. As soon as the cam clears the roller, the actuator will “bump” electrically towards the end of travel. Continue until the actuator reaches the full end of travel. If the actuator has over-traveled, rotate Cam 1 slightly counter-clockwise, then move the actuator towards the fail position electrically. Stop and electrically reverse the direction of travel. Move the actuator until Cam 1 operates switch 1 and the actuator stops. Repeat this procedure until the actuator is properly positioned.
 - g. If the actuator has over-traveled, rotate Cam 1 slightly clockwise, then move the actuator towards the fail position electrically. Stop and electrically reverse the direction of travel. Move the actuator until Cam 1 operates switch 1 and the actuator stops. Repeat this procedure until the actuator is properly positioned.
 - h. Rotate Cam 3 until it comes in contact with Switch 3’s arm roller and the switch just “breaks”. A light “click” can be heard. Rotate the cam slightly further in the clockwise direction. This ensures that Switch 3 will “break” just prior to the actuator reaching the extreme opposite end of travel. Tighten the setscrews on Cams 1 and 3.
6. Operate the actuator electrically several times to ensure proper operation and to verify that travel limits and stops are correctly set.
 7. De-energize the actuator to verify proper spring failure operation. Ensure the driven device is properly positioned in the spring failure position.
 8. If the actuator is supplied with an optional feedback potentiometer and/or position controller, verify proper calibration of input and output signals after making cam and stop bolt adjustments.
 9. Replace the actuator cover and cover screws.
 10. The actuator is now ready for electrical operation.

Spring Drive CW On Loss of Power

Figure 2 (For Illustration Purposes only)

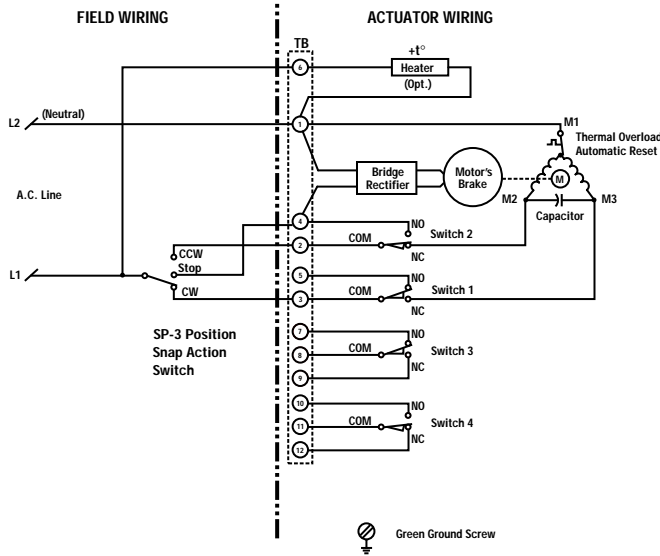

Motor drive both CCW & CW
intermediate stop capability
spring drive CW on loss of power.

Operation Notes:

- A. Power to terminal 1 & 2 will motor drive and brake hold actuator in CCW most position if the brake is energized at terminal 1 & 4 when switch N.O. of SW2 closes.
- B. Power to terminal 1 & 4 will brake hold actuator in whatever position it is in at the time.
- C. Power to terminal 1 & 3 will motor drive and spring hold actuator in CW most position.
- D. Loss of power will spring drive and spring hold actuator in CW most position.

Spring Drive CCW On Loss of Power

Figure 3 (For Illustration Purposes only)

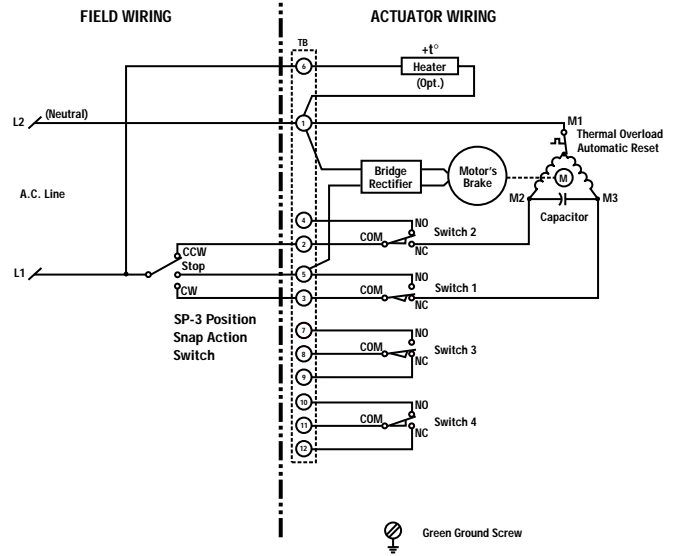

Motor drive both CCW & CW
intermediate stop capability
spring drive CCW on loss of power.

Operation Notes:

- A. Power to terminal 1 & 3 will motor drive and brake hold actuator in CW most position if the brake is energized at terminal 1 & 5 when switch N.O. of SW1 closes.
- B. Power to terminal 1 & 5 will brake hold actuator in whatever position it is in at the time.
- C. Power to terminal 1 & 2 will motor drive and spring hold actuator in CCW most position.
- D. Loss of power will spring drive and spring hold actuator in CCW most position.



SURE 100

NEMA 4, 6, 7 AND 9 DIMENSIONAL INFORMATION

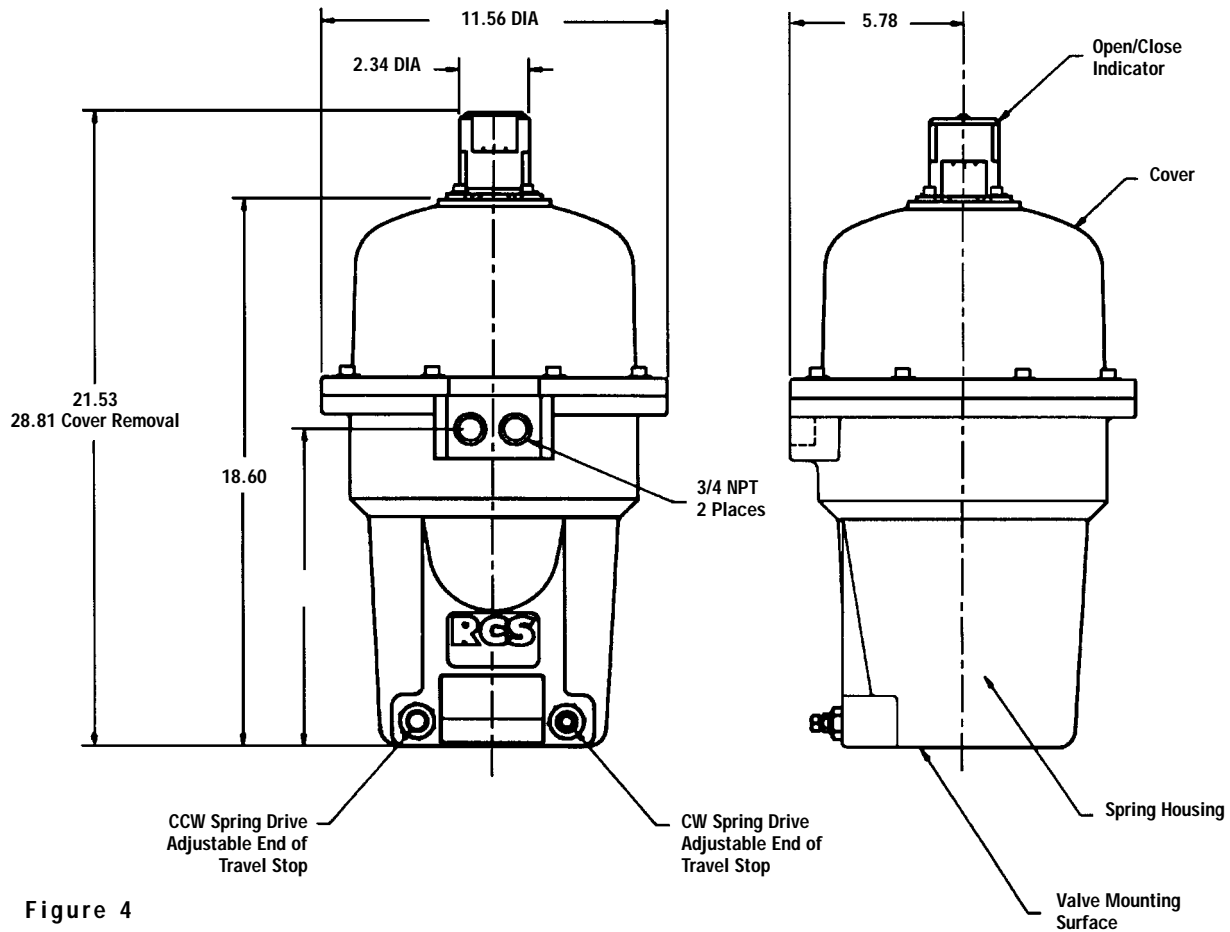

Figure 4

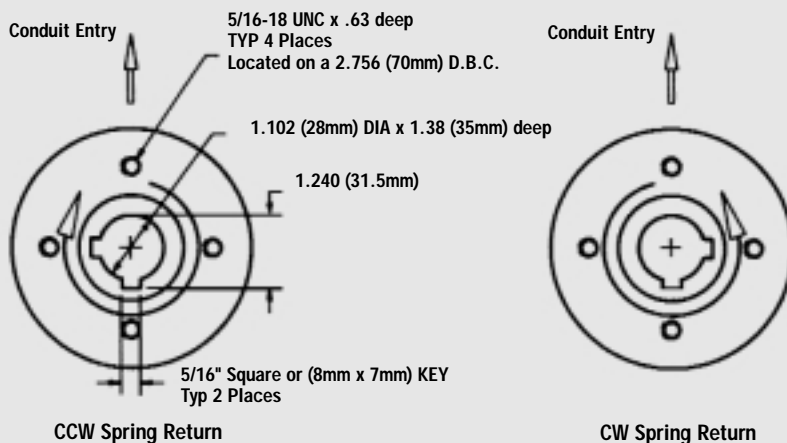

Figure 5

NOTES

1. Direction of rotation is based on viewing actuator from top.
2. Actuator shown in power fail position.
3. Mounting geometry complies with ISO 5211 flange type F07 (except bolt thread).
- *4. Two keys are recommended for driving device.

Dwg. No. 90-853



SURE 100



To prevent ignition of hazardous atmospheres,
do not remove actuator cover while circuits are live.



Operation

Power On: The electric motor drives the gear train, which in turn winds the spring and turns the device. An internal limit switch de-energizes the motor and the brake, which holds the return spring and device in position.

Power Off: When the current is interrupted by either a control signal or a power failure, the return spring drives the device to its original position.

Note: It is recommended that the actuator be driven electrically in both directions for normal operation to prolong cycle life.

Maintenance

Gear train is permanently lubricated at the factory for the average life of the actuator. No further attention is required.

Thermal Overload

The internal thermal overload switch de-energizes the motor and prevents overheating of the motor windings due to excessive operation, stalling or high ambient temperatures.

Duty Cycle

The maximum duty-cycle to be expected without interruption by thermal cut-off at an ambient temperature of 65C° is 25% (3 "OFF" times for every 1 "ON" time) for the 5 and 10 second design, and 50% (1 "OFF" time for every 1 "ON" time) for the 30 second design.

Storage

The Surepowr actuator must be stored in a clean, dry, temperature controlled building which is protected from the weather. Precautions shall be taken to prevent condensation inside or outside the actuator. If there is insufficient external temperature and humidity control, internal heaters must be installed and energized to protect the unit against condensation from extreme temperature variations. The actuators shall be stored off the floor on suitable pallets and must be covered with an unsealed dust protector allowing side and bottom ventilation.

Troubleshooting (New Unit)

Note: Most actuator problems occur due to incorrect cam/travel limit switch setting, or the use of an external travel stop on the device that the actuator is operating.

Problem 1: Actuator is receiving electric power but the motor does not respond.

Instructions: 1a. Check actuator nameplate to insure correct model, voltage type and spring return direction.

1b. Check all wiring against installation wiring diagram.

1c. **Actuator with clockwise fail position:** Using a volt meter, check that power is available between terminals 1 and 2. Then check the voltage between terminal 1 (common) and the two legs of the motor and capacitor. The meter should indicate a value equal to or greater than the supply voltage indicated on the actuator nametag.

Actuator with counter-clockwise fail position: Using a volt meter, check that power is available between terminals 1 and 3. Then check the voltage between terminal 1 (common) and the two legs of the motor and capacitor. The meter should indicate a value equal to or greater than the supply voltage indicated on the actuator nametag.

If power is not present at the motor or capacitor leads:

- Cam adjustments are required
- Switch malfunction
- Improper wiring



Problem 2: Actuator is receiving electric power but the motor only hums.

Instructions: 2a. Perform steps 1a through 1c listed above.
2b. Check to insure the brake is completely disengaged when power is applied.

Problem 3: Actuator runs but operation is erratic.

Instructions: 3a. Perform steps 1a through 1c listed above.
3b. Check ambient temperature. Standard Surepowr actuators have a maximum ambient operating temperature rating of 65°C.
3c. Check duty cycle (frequency of operation). See above for details.
3d. Ensure that actuator is not continuously stalled.

Problem 4: Motor runs continuously in spring return direction after actuator output shaft has stopped.

Instructions: 4a. Adjust spring return side travel cam/switch so that the cam trips the switch before the shaft stops motion.

Problem 5: Motor runs continuously but output shaft does not turn.

Instructions: 5a. Check for power to the bridge rectifier and clutch solenoid.

Note: Standard Surepowr actuators are manufactured with thermal overload protectors in series with the motor common. Should any of the above problems cause the protector to open, it will automatically reset when the motor temperature is lowered to a safe level.

Locating and Ordering Parts

For ease and accuracy in identifying and ordering spare or replacement parts, submit the following information from unit nameplate.

1. Serial Number
2. Model Number
3. Voltage

